

DOUBLE WALL HDLPE STORAGE TANK, CYLINDRICAL.  
 THE CONTAINMENT TANK IS DESIGNED TO HOLD A  
 MINIMUM 115% OF THE PRIMARY STORAGE TANK.  
 DESIGNED FOR ABOVE-GROUND, VERTICAL INSTALLATION,  
 CONTAINING PRODUCT AT ATMOSPHERIC PRESSURES.

RevNo	Revision note	Date	Signature	Checked

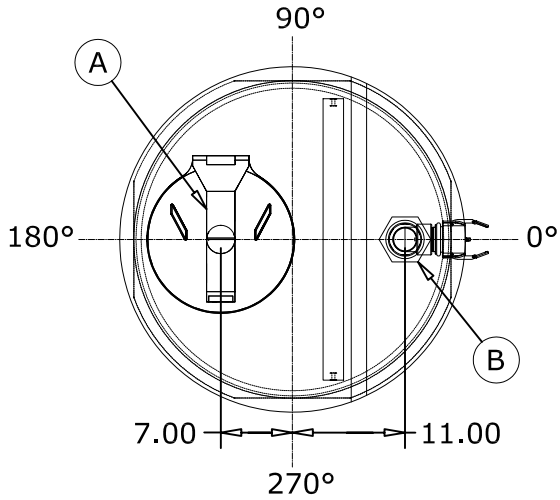

BAR CODE LABEL

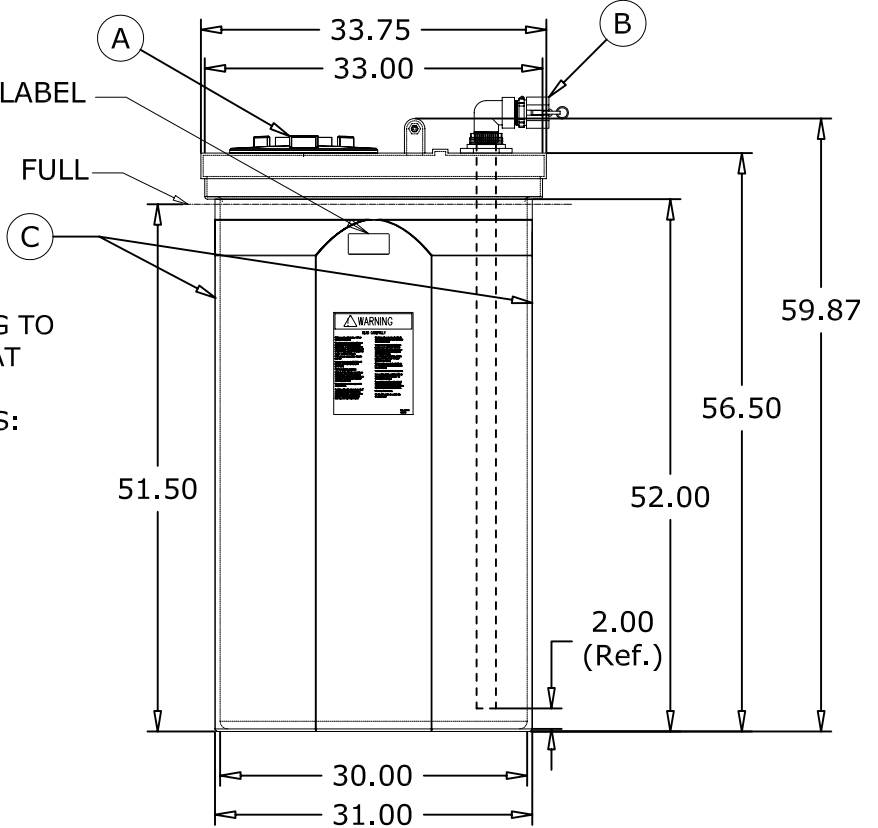

THE FOLLOWING TO  
 BE STENCILED AT  
 0° AND 180° IN  
 2" TALL LETTERS:  
 USED OIL  
 ONLY

- A. ASM MANWAY HINGED PP 12IN HYPRO/ARAG [P/N 34700557]
- A. STRAINER BASKET 12" PP HYPRO/ARAG # 300330 [P/N 24100191] - NOT SHOWN
- B. FITTING PE 2IN BH TXT EPDM BJO [P/N 34300119]
- B. ASM DRAWTUBE PP EPDM 120-150 DCT [P/N 34700332]
- C. INK BLACK STENCIL MARSH ROLLMARK [P/N 99200011]
- D. PROTECTIVE PLASTIC PACKAGING FOR SHIPMENT [P/N 00000017] - NOT SHOWN

TANK ASSEMBLY #: 1000400N89102 (L)  
 PRIMARY #: 5710000N95701 (L)  
 HDLPE/BLACK/1.9 SG.  
 CONTAINMENT #: 1000400N89101 (L)  
 HDLPE/YELLOW/1.9 SG.

ALL DIMENSIONS IN INCHES

P.O. #	PN 1000400N89102 150 GAL USED OIL STORAGE			Article No./Reference	
Designed by C.GORTON	Checked by XXX	Approved by - date APPROVED_BY_DATE	File name FILENAME	Date DATE	Scale NTS

This drawing and design is the property of SIERRA SALES.  
 It may not be used for any purpose other than by the owner.  
 SIERRA does not authorize the reproduction or conveyance of any  
 information contained herein without prior written permission.

**SIERRA**

Perkasie, PA 18944 USA 215-258-5602

**TITLE**

DWG.NO.:

Revision  
0  
Sheet  
1/1