

RevNo	Revision note	Date	Signature	Checked
-------	---------------	------	-----------	---------

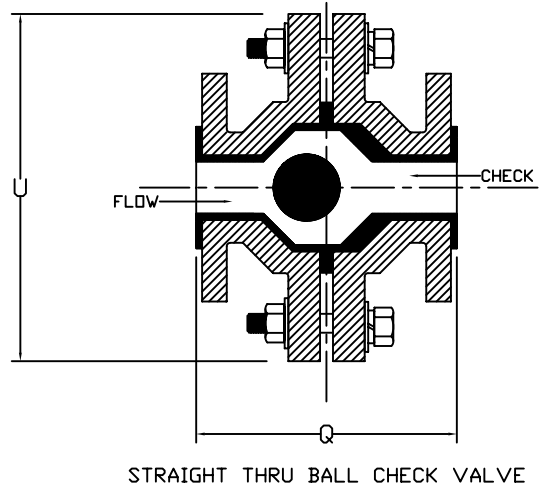
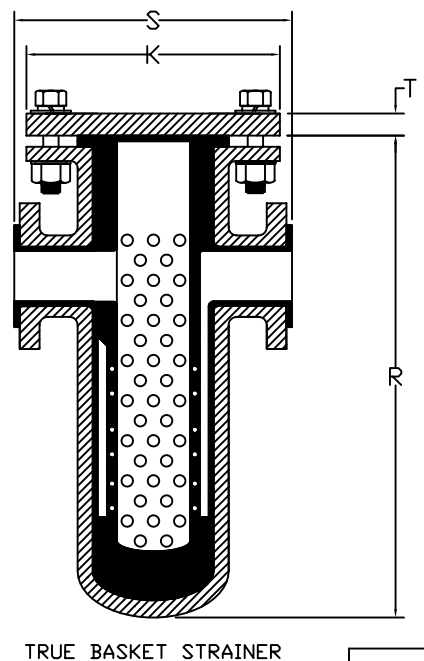
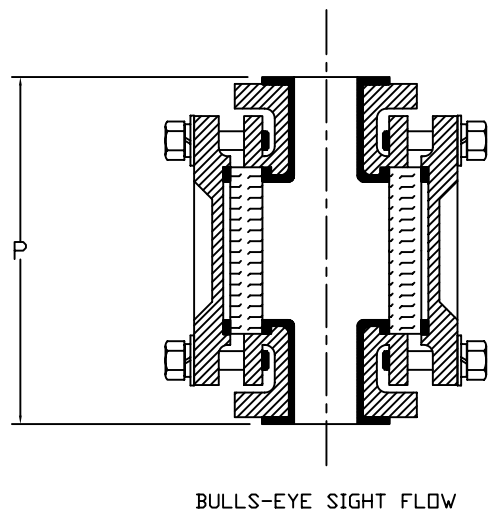
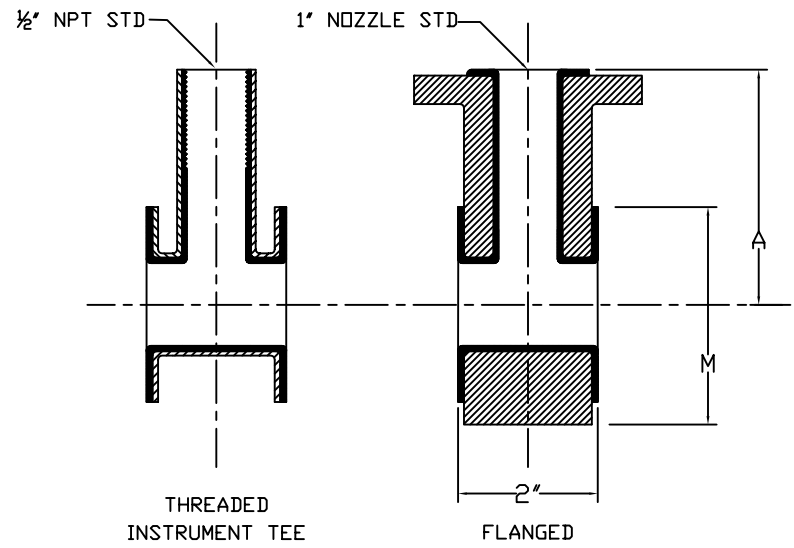

CV

1"	- 40
1 1/2"	- 90
2"	- 200
3"	- 335
4"	- 400
6"	- 625

ALL DIMENSIONS FACE TO FACE INCLUDING LINER MATERIAL

P.O. #	PLASTIC LINED FLANGED FITTINGS			ALL DIMENSIONS IN INCHES	
Designed by C.GORTON	Checked by CHECKED_BY	Approved by - date APPROVED_BY_DATE	File name LS-SSMC	Date 12/05/05	Scale NTS

This drawing and design is the property of SIERRA SALES. It may not be used for any purpose other than by the owner. SIERRA does not authorize the reproduction or conveyance of any information contained herein.

SIERRA
Perkasie, PA 18944 USA 215-258-5602

LINED STEEL FITTINGS

DWG.NO.:LINEDFITTINGS-D03-A	Revision 0	Sheet 1/1
-----------------------------	---------------	--------------

**150 LB. DIMENSIONS FOR INSTRUMENT TEE, BULLS-EYE SIGHT FLOW,
BALL CHECK VALVE AND BASKET STRAINER**

SIZE	A	K	M	P	Q	R	S	T	U
1	3 1/2	5	2 5/8	7	6	10 1/2	8 1/4	13/16	6
1 1/4	3 3/8		3		O/A				O/A
1 1/2	4	6	3 3/8	8	7	11 1/4	9	15/16	7
2	4 1/2	7	4 1/8	9	7	12	9 7/8	1	7 1/2
2 1/2	5	7 1/2	4 7/8	10	O/A	14	10 7/8	1 1/8	O/A
3	5 1/2	7 1/2	5 3/8	11	8	14	10 7/8	1 1/4	10
4	6 1/2	10	6 7/8	13	10 1/2	18 1/2	15 3/4	1 3/8	12
6	8	13 1/2	8 3/4	16	15 1/2	27	20	1 9/16	16
8	9	16	11	18	19	36	22	1 3/4	19

1. All dimensions are in inches and include lining. Tolerance $\pm 1/8"$.
2. All fittings have plastic molded raised faces. Minimum gage diameters are same as pipe.
3. Fittings can be made with special dimensions or angles other than standard when required.
4. All fittings conform to ANSI B 16.1 or B 16.5 dimensions after lining.
5. Any fitting required is available including ANSI Class 600 or higher.
6. Larger fittings available. Dimensions on request.

Sierra Sales
346 Kent Lane, Perkasie, PA 18944
PHONE 215-258-5602
FAX 215-258-5606
www.petanks.com